

ת.י.א.א.א. הנדסה בע"מ

08.03.2018

מאשר
 מאת
 רשמי

שם: _____
 תפקיד: _____
 טלפון: _____
 חתימה: _____
 תאריך: _____

יש לציין לפרט אוררוך בראש הציף בקיר הפונה לאוררוך החופשי.
 (לא בתוקף) גודל תחמת ירידה לחד 0.5 מטר. נטו. דטאיל Counterweight Detail
 Section A-A 1:50

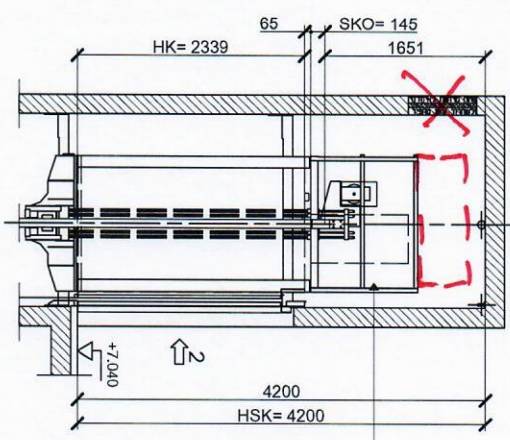
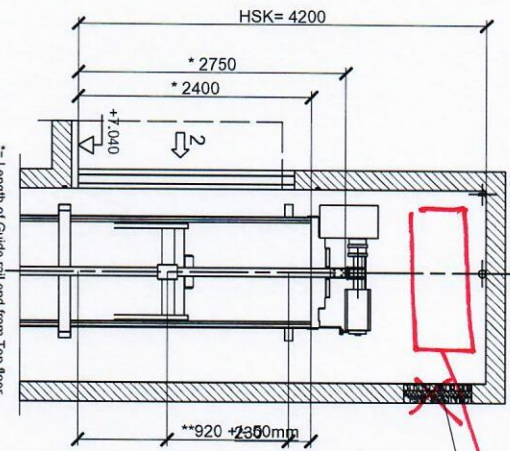

Section A-A 1:100

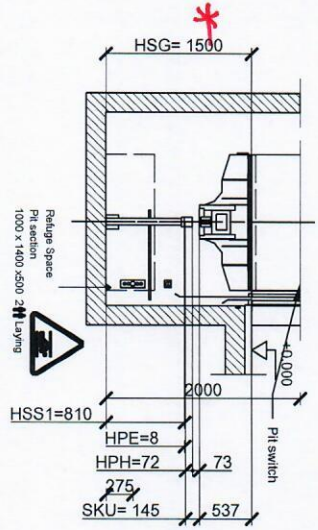
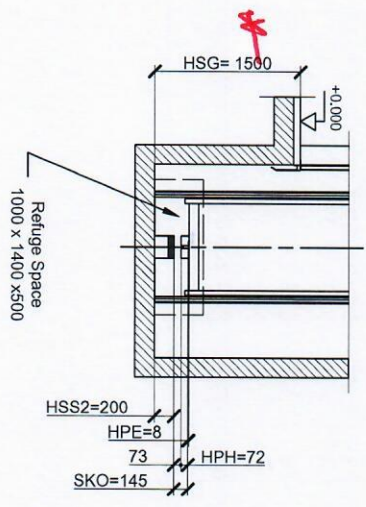
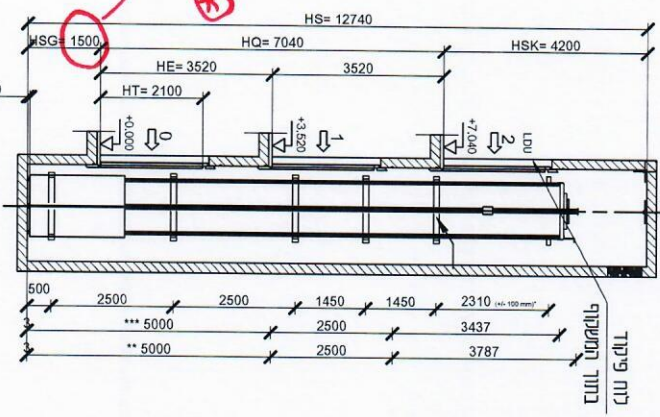

Hfmax=3000 mm
 * Guard for counterweight
 - Car guides
 *** Counterweight guides

Butters:	Car	Counterweight
Comm. No.	A	A
Length (mm)	72	72
Compression, HPH (mm)	8	8
Length compressed, HPE (mm)	8	8

- HT= height door
- HE= height floor
- HK= Car height
- HQ= height travel
- HS= height shaft
- HSG= height shaft pit
- HSK= height shaft headroom
- HSS1= height of plinth underneath car
- HSS2= height of plinth underneath counterweight
- SKU= lift overtravel (bottom)
- SKO= lift overtravel (top)

LAYOUT

Installation place: _____
 משרד: מעבדת ארזות שער בניקין

Schindler Nachshthan Elevators Ltd
 Grant
 Petach Tikva

Tel. 972 3 7214400
 Fax 972 3 7214405

Product Line: EN81-20/50 3300



Further inquiries concerning this plan on

Mis מידע: תל. 972 3 7214400

Tel. 972 3 7214400

Fax 972 3 7214405

Drawn	Released	Page
AVAD	TLV0011096755	2
	TLV0011096756	
	0011096756.101	



